

## ABOUT AAGARD

Aagard is a world-class manufacturer of industrial automation and packaging machinery with an intense focus on production capability and total project success. We design, manufacture, and prove each system we build in Alexandria, Minnesota. Our growing work force of creative and highly skilled employees allows us to develop imaginative solutions and build you efficient machinery of the highest quality.

Aagard's Combination Systems increase productivity while minimizing floor space, labor, and utility requirements. Using proven technologies, Aagard has developed unique packaging solutions that combine sleeves, retort loaders/unloaders, cartoners, case packers, palletizers, accumulators and many smaller unit operations all into a common frame and controls system.

With Aagard's intense focus on "Production Capability" on every project, many aspects including safety, capability, and reliability are carefully considered. This starts at the beginning with a detailed engineering planning phase that includes detailed timing charts per SKU as well as 3D design reviews with your team. Later, this planning is proven with a thorough testing phase focusing not only on normal operation, but also on machine recovery. Each machine is proven with a complete FAT process which allows Aagard to partner with our customers for total project success.

We welcome the opportunity to demonstrate how we create, control, and analyze motion in proven applications that you may not have seen before. Let Aagard use our innovation to create the optimum solution for your next project!

# Aagard

3711 Iowa Street  
Alexandria, MN 56308  
p: 320.763.6043  
w: [www.aagard.com](http://www.aagard.com)  
e: [sales@aagard.com](mailto:sales@aagard.com)



**TRAY LOADERS**  
**CARTONERS**  
**CASE PACKERS**  
**MULTI-PACKERS**  
**PALLETIZERS**



# Aagard

**WINNING TOGETHER HONORABLY**

## COMBINATION SYSTEMS

Tray + Carton + Mega Carton + Case + Pallet



- Automatic cartridge collation, tray loader, cartoner, mega pack cartoner, case packer, palletizer system
- 1000 rounds per minute (20 cartons)
- Capable of wide variety of centerfire pistol cartridges (.380 thru .45) with reliable changeover
- One operator and controller for entire system
- Small footprint
- Aagard's unique dagger board cartridge collation
- Integrated vision inspection
- Automatic tray reject and refeed prior to cartoner
- Automatic carton, mega carton, and case rejects
- Positive carton setup and handling
- Several integrated devices including six cameras, five printers, and three bar code scanners
- Three-axis robot for combined case packing and palletizing operations



## CASE PACKER + DUAL PALLETIZER

- Three-axis gantry device with optimized motion maximizes machine performance and longevity
- Servo-powered case shuttle advances cases through loading, flap closing, and sealing for complete motion control
- Two-axis funnel prevents loading jams
- Integrated open flap detection and taper verification ensures the quality of each case
- Dual-cell palletizing allows for the first pallet to be removed while the second is being built without interrupting the packaging process
- Telescoping infeed conveyor allows continuous flow while someone passes through the line
- Up to 60 cartons per minute depending on pack pattern (limited by case rate)
- Slow, controlled motion with positive case closing devices (no plows)

Automation for many ammunition types:

- Rimfire
- Shotshell
- Centerfire Pistol
- Centerfire Rifle



Machine Features include quick changeover between many calibers, SKU's, and material sizes.

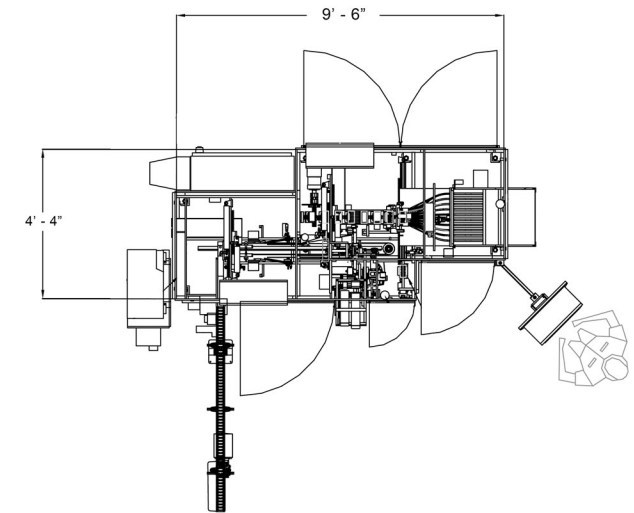

## HIGH SPEED CARTONER

- Automatic shotshell cartoner
- 750 rounds per minute (30 cartons)
- Servo-controlled motions for high speed reliable operation
- Positive carton setup and handling
- Starwheel collation system
- Two-axis loader with separate follower for reliable carton loading
- Carton cleanout feature to quickly clear bad cartons
- Servo-powered funnels for flap closing
- Arthur lock (tuck tabs) on minor flaps
- Integrated carton printing and bar code scanning
- Automatic reject

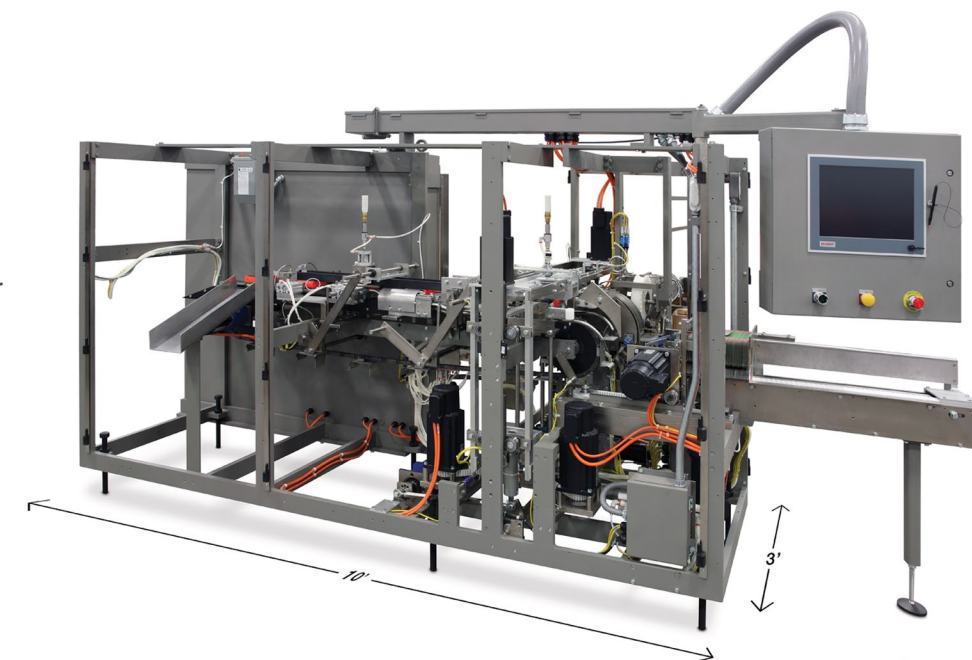

## TRAY LOADER + CARTONER

- Small footprint machine designed for maximum reliability and throughput
- Rockwell control system with dual language support (English/Spanish)
- High speed mechanical cartridge collation
- Collates cartridges, loads trays, forms and seals cartons at up to 180 cartridges per minute
- Aagard manufactures similar systems with speeds of 1000 or more cartridges per minute